

Exploring the boundaries of materials science or device development?

Learn the latest techniques for ensuring electrical measurement accuracy



Learn how you can get better correlation of results when you perform multiple measurement types on a single system

Characterizing a semiconductor device, material, or process thoroughly requires the ability to make three types of measurements: precision DC I-V measurements, AC impedance measurements (often made with a C-V meter), and ultra-fast or transient I-V measurements. Until recently, labs might have required three separate test systems to obtain all three measurement types. In addition to added expense, using multiple systems makes it difficult to combine different measurement types in a single application or to correlate the results from different types of measurements accurately. [Learn more.](#)

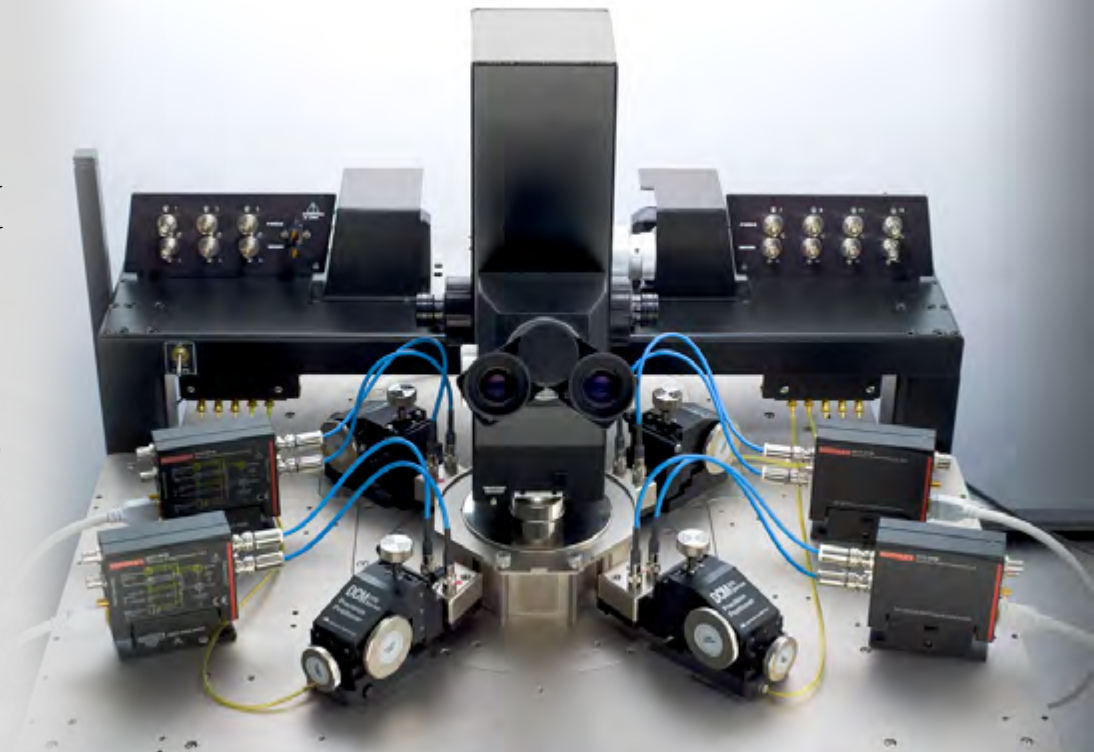

Investigate how to get better results correlation at a lower cost. Download our **free white paper.**

Remote amplifier/switches and the multi-measurement performance cabling used to connect them to the probe manipulators on the wafer prober are critical to integrating accurate ultra-fast I-V, C-V, and precision DC I-V measurements into the same parametric analysis system.



Let us offer advice on your application. **Contact an applications engineer online.**

Tackle multiple test challenges with the Model 4200-SCS Semiconductor Characterization System

Only the **Model 4200-SCS Semiconductor Characterization System** can handle all three measurement types: precision DC I-V, AC impedance, and ultra-fast I-V or transient I-V. Low current measurement resolution can extend to 0.1fA. Capacitance measurements range from femtoFarads (fF) to nanoFarads (nF) at frequencies from 1kHz to 10MHz. And ultra-fast I-V sourcing and measurement is as easy as making DC measurements, and fast: measure both voltage and current simultaneously for up to one million samples at 5ns per sample.

Bundled Characterization Solutions Available
 Learn how to get more for your capital budget with Keithley's bundled characterization solutions. [Learn more now.](#)

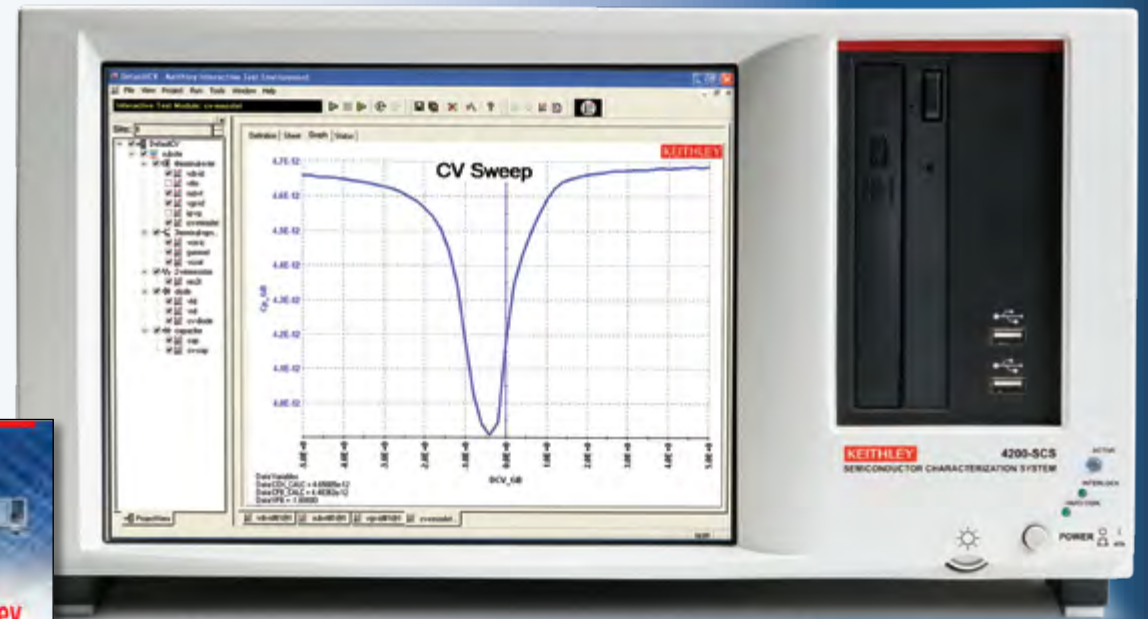

Need more details? **Download the Model 4200-SCS data sheet.**

Ready to request a quote or place an order?
Contact us online.

Ultra-fast I-V testing of compound semiconductor devices and materials

Pulsed I-V testing is often performed on devices made from III-V materials, such as GaN, GaAs, and other compound semiconductor materials. These larger band gap devices are often used in higher power and RF devices. Pulsed I-V measurements make it possible to manage or investigate the effects of dispersion during electrical characterization. Sometimes it is necessary to test devices at higher frequencies in order to simulate the conditions the actual device will encounter in regular use. Laser diodes and power MOSFETs are two common compound semiconductor devices that often require pulse I-V measurements for characterization. [Learn more.](#)



Want to make ultra-fast I-V measurements?

Download our free guide to ultra-fast I-V applications.

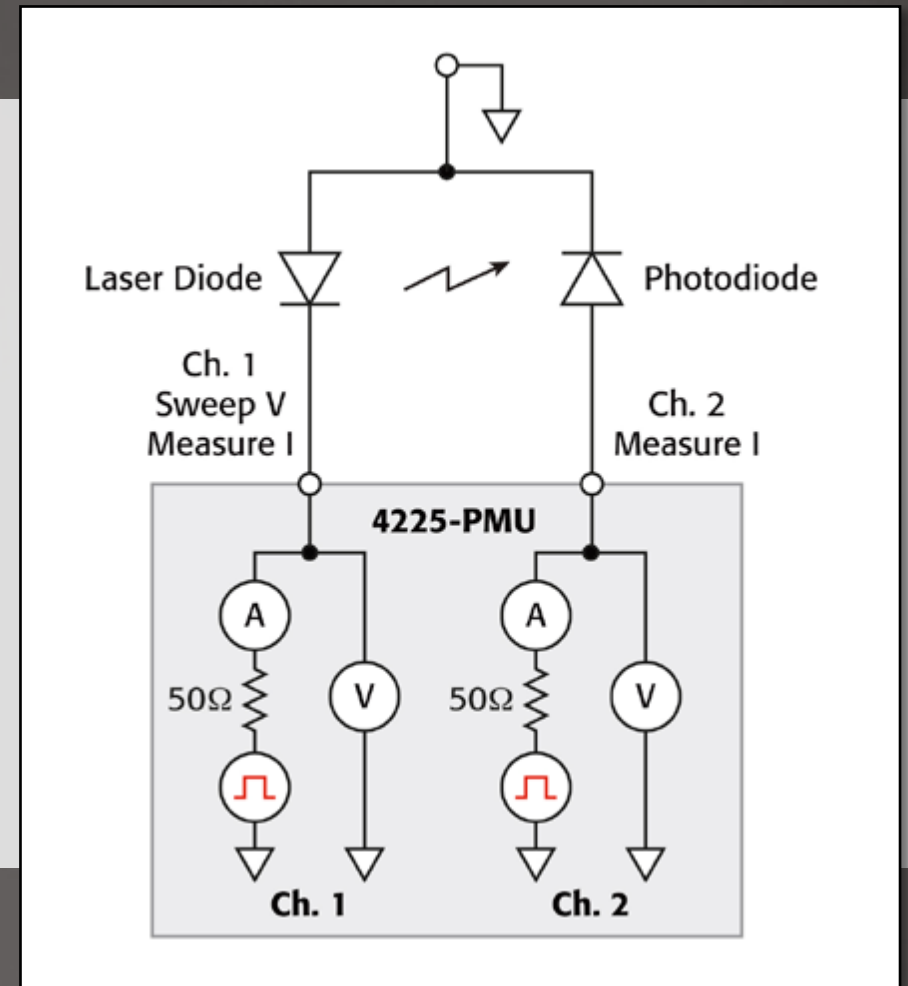

Laser diode test configuration



View our webinar on making ultra-fast measurements.



Let us offer advice on your application. Contact an applications engineer online.

Take control of ultra-high speed pulse sourcing and measurement with the Model 4225-PMU

The **Model 4225-PMU Ultra Fast I-V Module** is the latest instrumentation option for the Model 4200-SCS Semiconductor Characterization System. It integrates ultra-fast voltage waveform generation and signal observation capabilities into the Model 4200-SCS's already powerful test environment to deliver unprecedented I-V testing performance, expanding the system's materials, device, and process characterization potential dramatically. Just as important, it makes ultra-fast I-V sourcing and measurement as easy as making DC measurements with a traditional high resolution Source-Measure Unit (SMU).



Need more details? **Download our Model 4225-PMU data sheet.**

Ready to request a quote or place an order?
Contact us online.

Learn how to determine solar cell efficiency using the latest electrical characterization techniques

Some of the electrical tests commonly performed on solar cells involve measuring current and capacitance as a function of an applied DC voltage. Electrical characterization is important in determining how to make the cells as efficient as possible with minimal losses. Capacitance measurements are sometimes made as a function of frequency or AC voltage. Some tests require pulsed current-voltage measurements. These measurements are usually performed at different light intensities and under different temperature conditions. A variety of important device parameters can be extracted from the DC and pulsed current-voltage (I-V) and capacitance-voltage (C-V) measurements, including output current, conversion efficiency, maximum power output, doping density, resistivity, etc. [Learn more.](#)

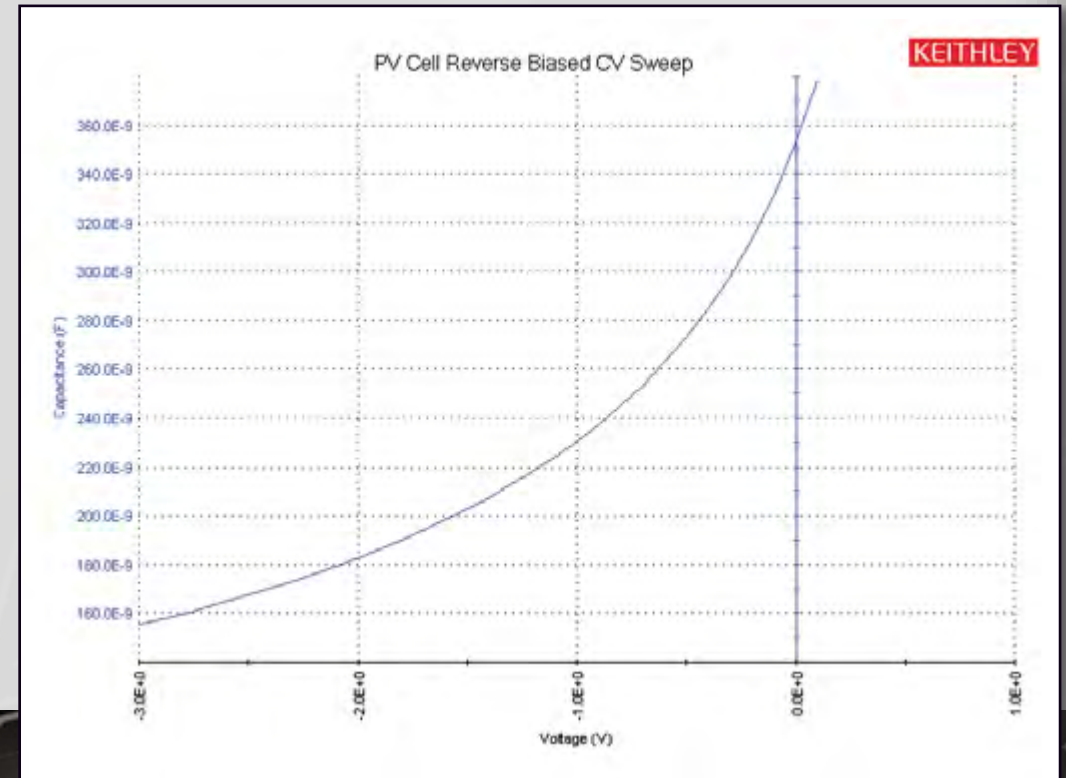

C-V sweep of a silicon solar cell



Discover how to make faster, more accurate C-V measurements on solar cells. [Download our application note.](#)



Let us offer advice on your application. [Contact an applications engineer online.](#)

Plug in to greater capacitance-voltage measurement capabilities with the Model 4210-CVU

The **Model 4210-CVU**, the Model 4200-SCS's optional capacitance meter, can measure capacitance as a function of an applied DC voltage (C-V), a function of frequency (C-f), a function of time (C-t), or a function of the AC voltage. The Model 4210-CVU can also measure conductance and impedance. The Keithley Test Environment Interactive (KTEI) package combines nine new solar cell test libraries with an expanded C-V frequency measurement range, which supports testing flat panel LCDs and organic semiconductors such as organic light-emitting diodes (OLEDs).



Need more details?
Learn more online.

Ready to request a quote or place an order?
Contact us online.

Learn Low Current Measurement Methods for New Devices/Materials

Low current (from nA to fA) electrical measurements are important for applications in semiconductor material/device characterization, nanoscience test and measurement, optoelectronic device characterization, and many more. Our archived online seminar describes low current measurement basics, including how to select the right current measurement instrument, practical ways to reduce current noise in measurement setups, and how to quantify subtle sources of noise. Application examples where such sensitive measurements are required will be discussed, together with a discussion of recent innovative test equipment solutions.

[Learn more.](#)

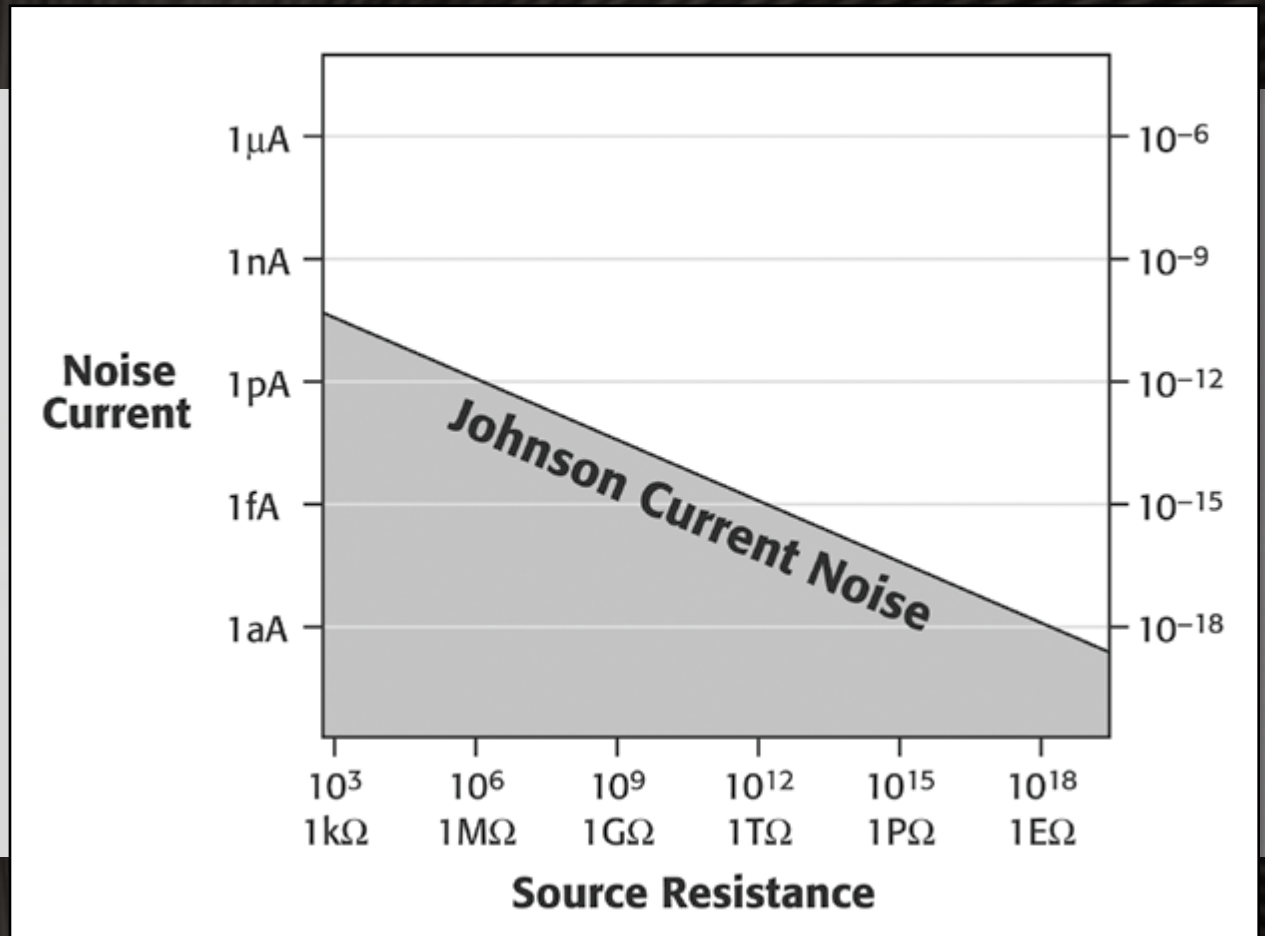

Johnson current noise is dependent upon many factors, including the source resistance of the DUT.

Learn about low current measurement methods for your application.
[View our online webinar.](#)



Let us offer advice on your application.
[Contact an applications engineer online.](#)

Get DC and pulsed measurements in the same box with Series 2600B System SourceMeter instruments

The **Models 2635B** and **2636B** are both the most sensitive (1fA) and the most powerful (10A pulse) members of the Series 2600A System SourceMeter family.

- Combines a power supply, true current source, DMM, arbitrary waveform generator, V or I pulse generator with measurement, electronic load, and trigger controller – all in one instrument
- 20,000 rdgs/sec provides faster test times and ability to capture transient device behavior
- Precision timing and channel synchronization (<500ns)
- LXI Class C compliance supports high speed data transfer and enables quick and easy remote testing, monitoring, and troubleshooting

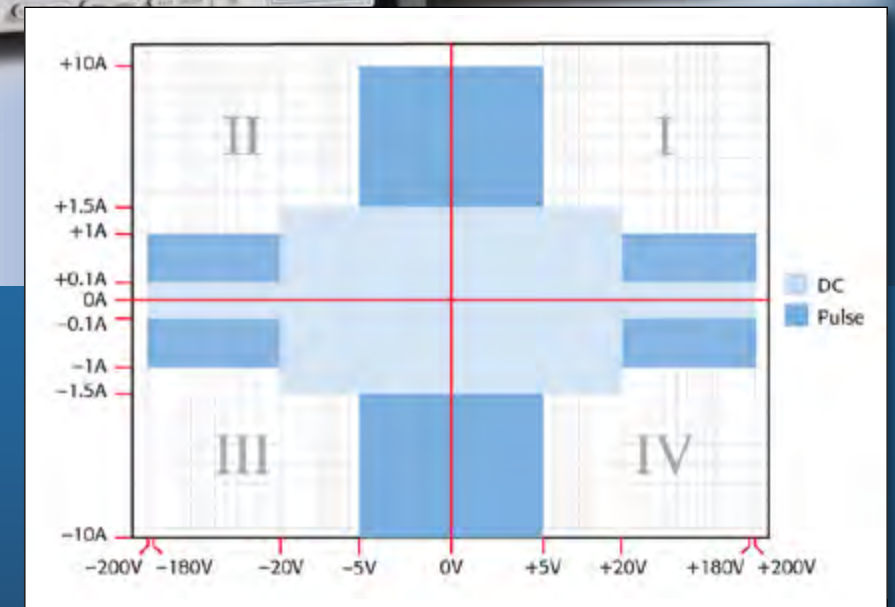

Models 2635B and 2636B capabilities



Ready to request a quote or place an order?
Contact us online.

Want to learn more about the Model 2635B and 2636B?
Download the Series 2600B datasheet.

Characterize your IC's quiescent current

Manufacturers of CMOS integrated circuits must measure their devices' quiescent or standby power supply current to verify quality during production testing. This I_{DDQ} testing process involves measuring the current of the V_{DD} power supply while the IC is in the quiescent state in order to check for shorted gate oxide and other IC defects that may cause a failure over time. Testing must be performed as quickly as possible to ensure acceptable throughput but also thoroughly to ensure product performance. [Learn more.](#)

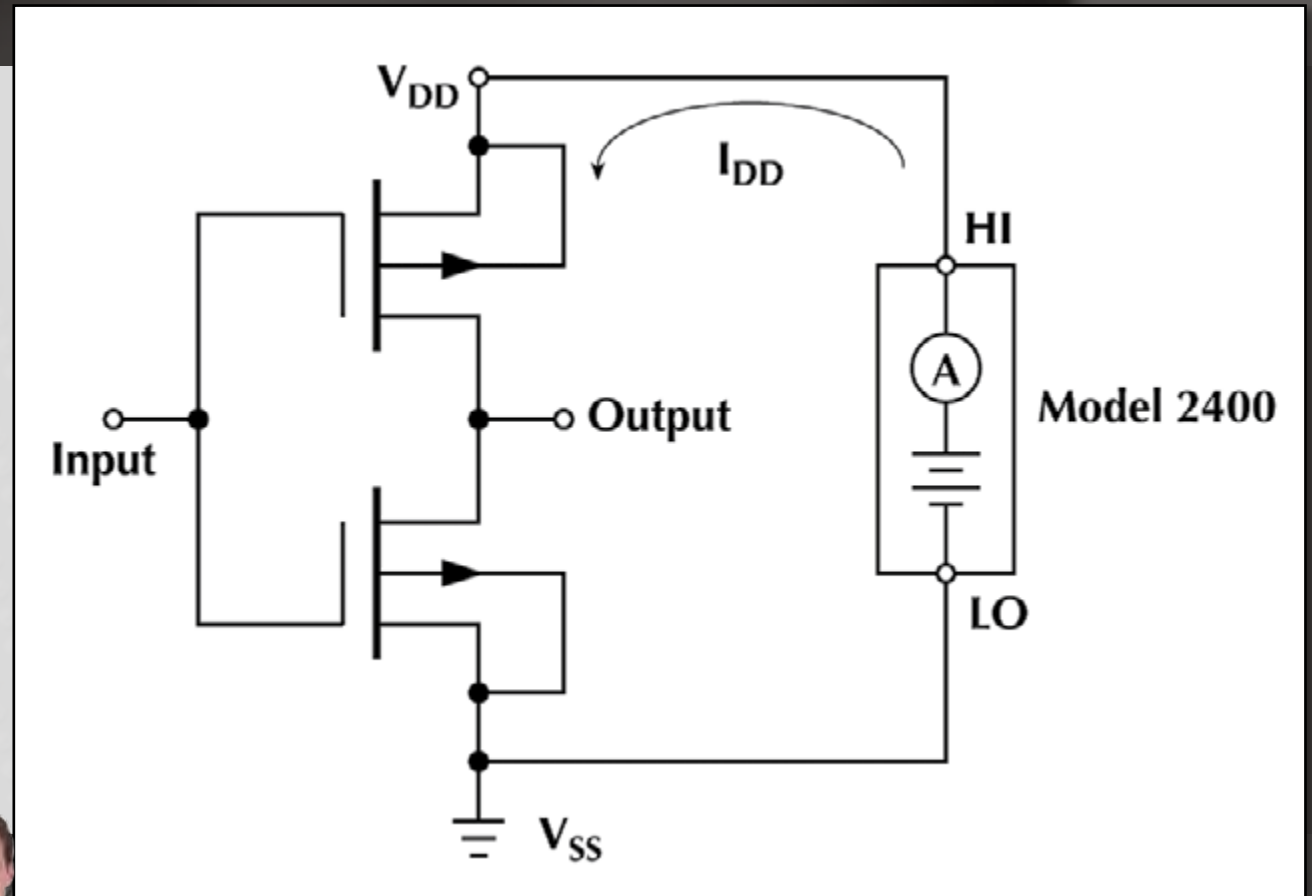

Measuring the quiescent current of a single CMOS inverter

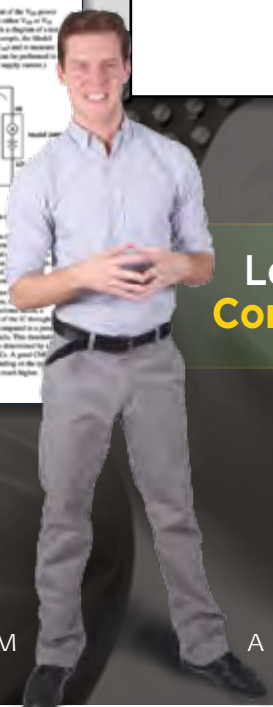

Learn more about I_{DDQ} testing.
[Download our application note now!](#)

Let us offer advice on your application.
[Contact an applications engineer online.](#)

Discover two great choices for applications that demand tightly coupled sourcing and measurement

The **Series 2400 SourceMeter® family** is designed specifically for applications that require tightly coupled sourcing and measurement. All SourceMeter models combine a highly stable DC power source and a true instrument-grade 6½-digit multimeter with high repeatability and low noise.

- The general-purpose **Model 2400** (200V, 1A, 20W) is suitable for testing a wide variety of devices, including diodes, resistors, resistor networks, active circuit protection devices, and portable battery-powered devices and components.
- Choose the **Model 2420** (60V, 3A, 60W) for testing higher power resistors, thermistors, I_{DDQ} , solar cells, batteries, and high current or medium power diodes, including switching and Schottky diodes.

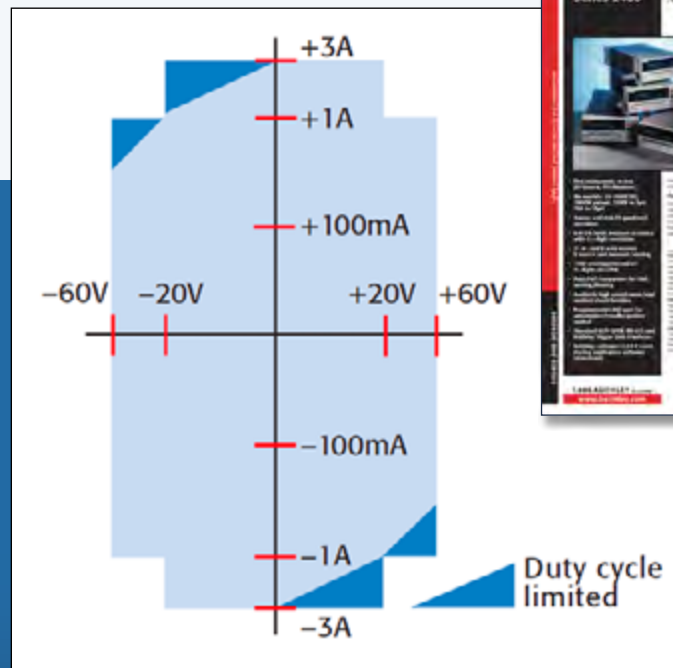
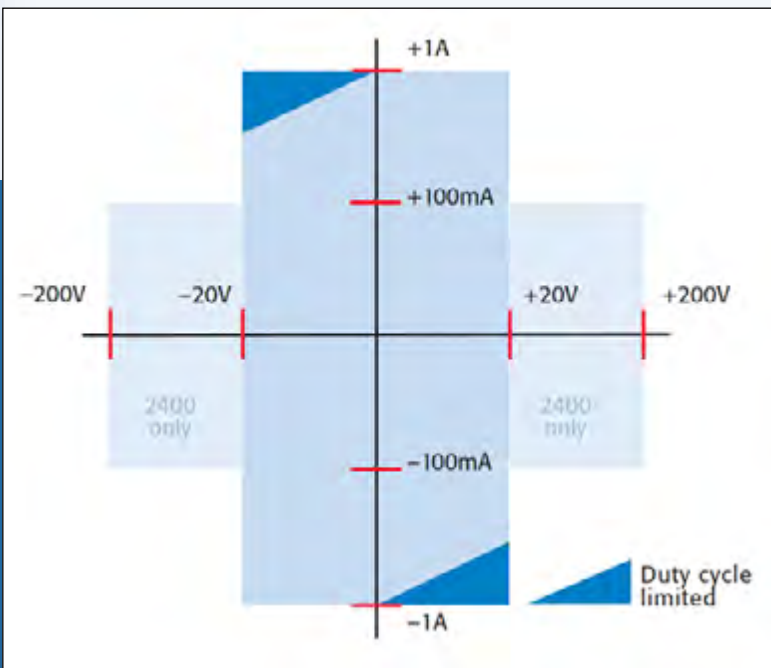

Need more details?
Download our Series 2400 datasheet.

Ready to request a quote or place an order?
Contact us online.

Model 2400 and 2420 Source and Measure Ranges

Explore the attoamp range on single electron devices

Researchers in R&D labs worldwide need ultra-low current measurement capabilities to investigate the properties of nanoscale components. Measuring currents of 100 attoamps or less is especially challenging: one attoamp ($1 \times 10^{-18} \text{A}$) corresponds to a flow of just six electrons per second. Today, however, it is possible to measure changes in current as small as one attoamp at room temperature using commercially available test and measurement equipment. [Learn more.](#)

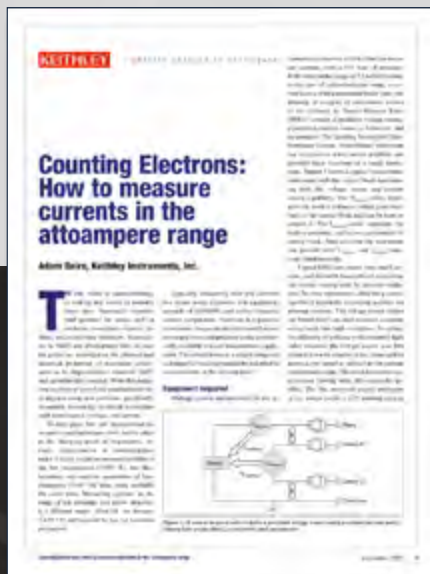

Delve into the latest techniques for low current measurements. [Read our article.](#)

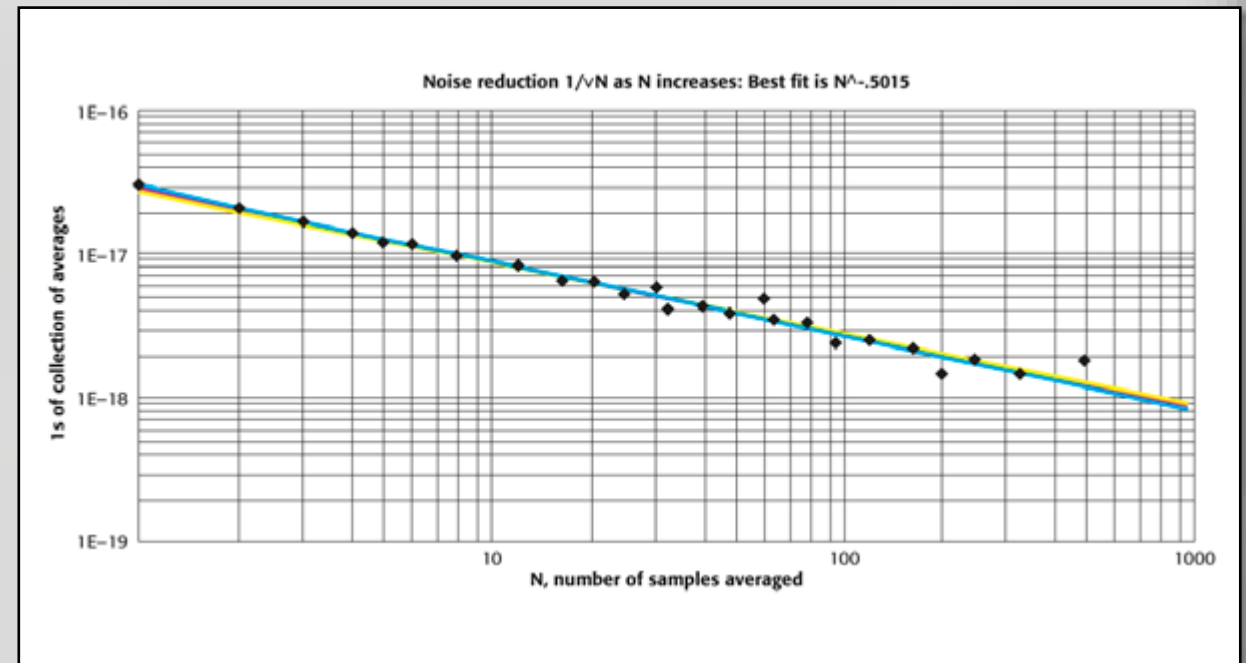

Using a slow staircase input instead of a simple DC signal shows that a discernable signal can be retrieved from the noise. After every 90 measurements (about 18 seconds), the current source was incremented by 10 attoamps. Inverting the staircase generated the negative source period.



Let us offer advice on your application. [Contact an applications engineer online.](#)

View our nanotechnology product tour.



Get unmatched measurements with the Model 6430 Sub-Femtoamp Remote SourceMeter instrument

The **Model 6430 Sub-Femtoamp Remote SourceMeter** combines the sourcing and measurement functions of an SMU with sensitivity, noise, and input resistance superior to electrometers. However, it makes voltage, current, and resistance measurements at speeds no electrometer can match. The Model 6430 is equally useful for research work and for evaluating sophisticated components in test labs.

- 0.4fA p-p (4E-16A) noise
- Remote PreAmp can be located at the signal source to minimize cable noise
- $>10^{16}\Omega$ input resistance on voltage measurements

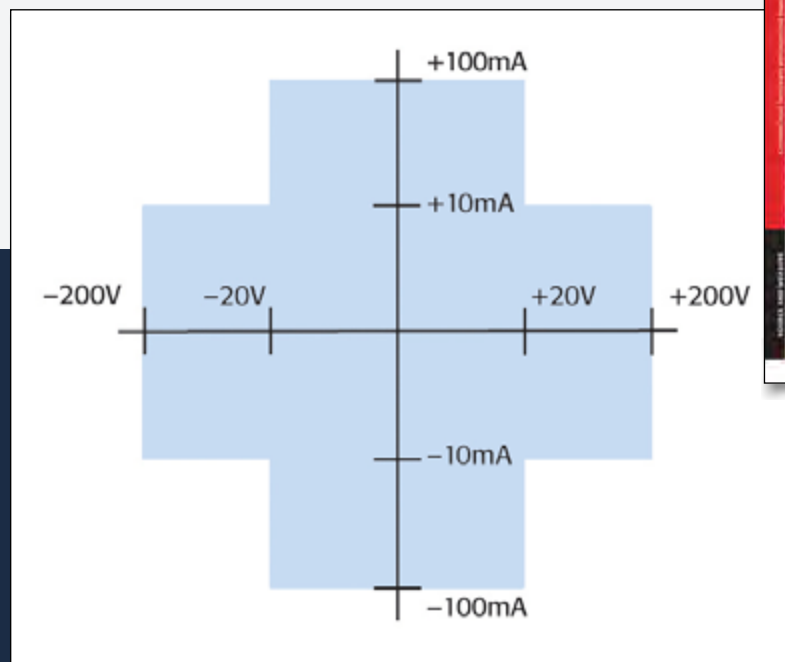

Model 6430 Capabilities



Want to learn more about the Model 6430?
Download the Model 6430 datasheet.

Ready to request a quote or place an order?
Contact us online.

Monitor and control focused ion beam currents

In semiconductor fabrication, focused ion beam systems are often used for nanometer-scale imaging, micromachining, and mapping. Careful monitoring of the magnitude of the beam current with an ion detector is critical. The ion detector generates a secondary current that's proportional to the current of the primary ion beam. When this secondary current is measured, it can be used to control the intensity of the primary beam. However, this secondary current is very low, often just a few picoamps, so the instrumentation measuring it must provide high measurement accuracy and repeatability, as well as sub-picoamp resolution. [Learn more.](#)

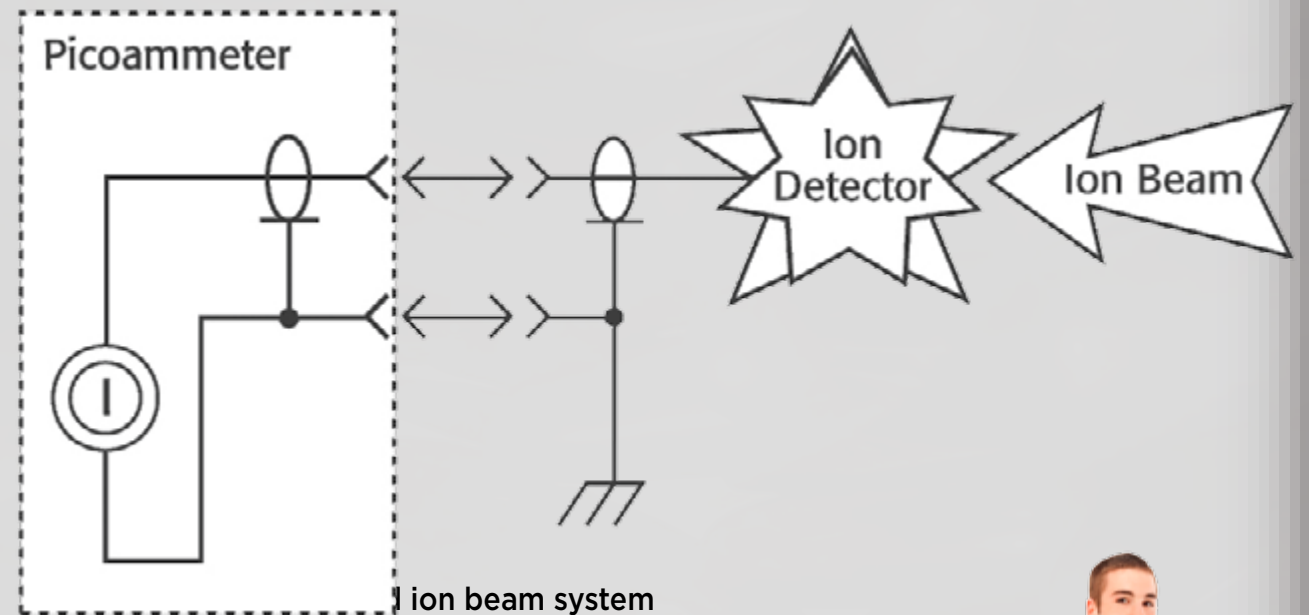

Discover economical tools for low current and high resistance measurements. [Download our picoammeter brochure.](#)

Let us offer advice on your application. [Contact an applications engineer online.](#)

[View our Low I, High Resistance demo.](#)



Discover where low cost meets high sensitivity with Keithley picoammeters

The 5½-digit **Model 6485 Picoammeter** combines sensitive current measurements with a robust, cost-effective design. With eight current measurement ranges and high speed autoranging, it can measure currents from 20fA to 20mA at up to 1000 readings per second. Its 10fA resolution and superior sensitivity make it well suited for characterizing low current phenomena. The **Model 6487 Picoammeter/Voltage Source** adds a high resolution 500V source to the Model 6485's measurement advantages, and provides higher accuracy and faster rise times, as well as a damping function for use with capacitive devices. Alternating Voltage resistance measurements make it well suited for characterizing low current devices.

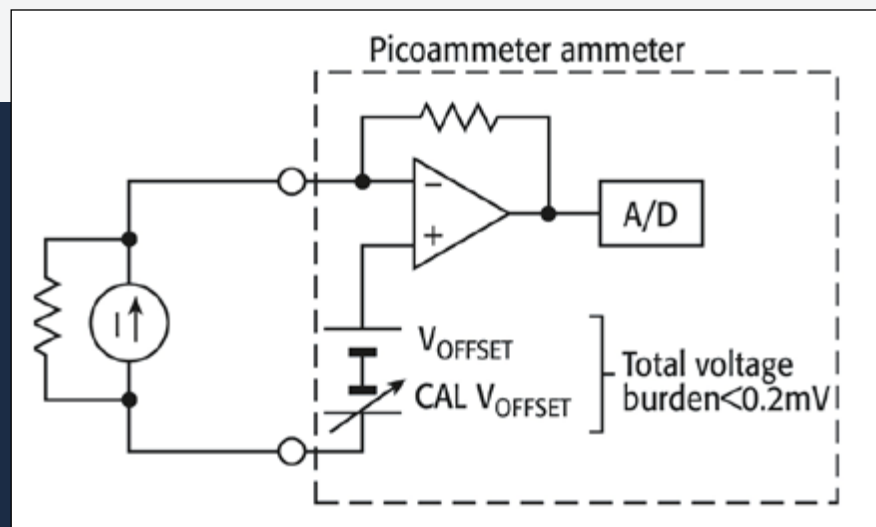

Unlike DMMs, picoammeters like the Model 6485 and 6487 employ a feedback ammeter design that reduces voltage burden dramatically for better measurement accuracy.



Want to learn more about these instruments?
Download the Model 6485 or Model 6487 datasheet.

Ready to request a quote or place an order?
Contact us online.

Learn about Hall Effect, an essential tool for studying Graphene-based nano-materials

In order to explore the potential for graphene-based nano-materials and other new materials, researchers increasingly turn to Hall Effect measurements. Hall Effect measurements are used to determine electrical properties, such as carrier mobility. With them, researchers are able to analyze quantum Hall Effects on one atom thick graphene structures. [Learn more.](#)



Test Setup for Both Hall Effect Measurements and Transverse Magnetoresistance Measurements (magnet and cryogenic chamber not shown)

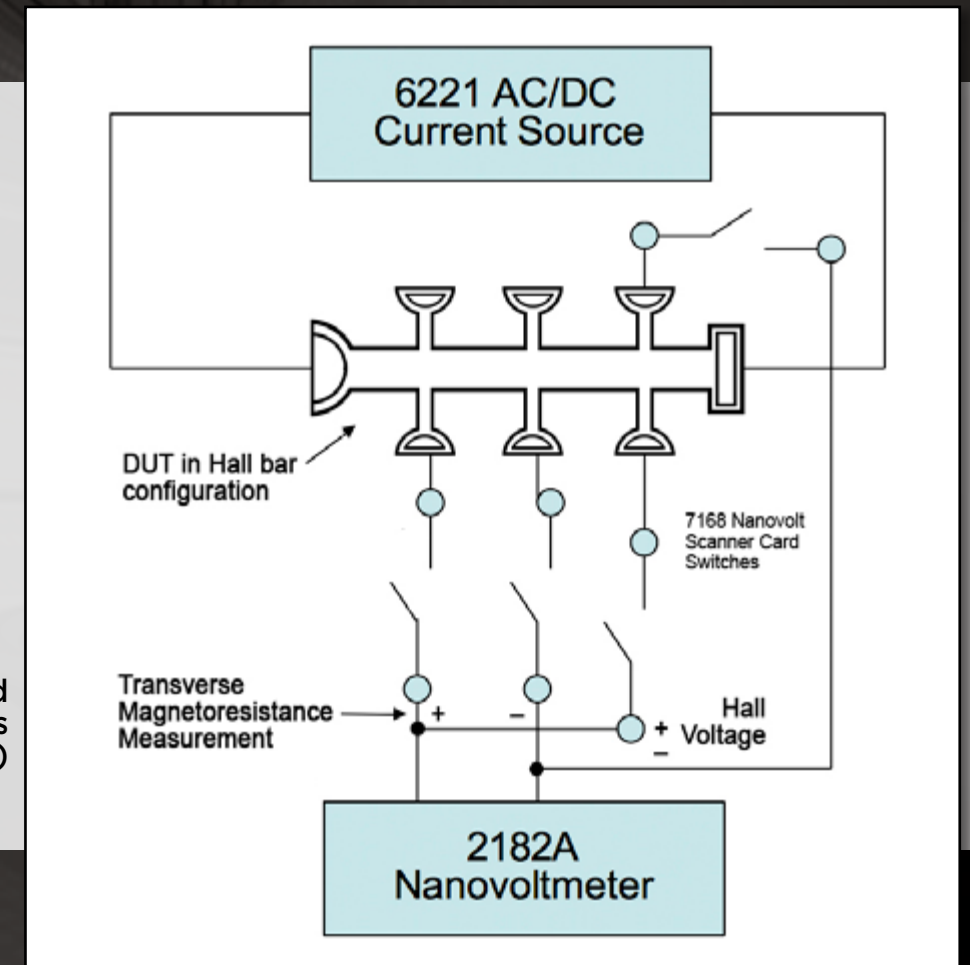

Want to learn more? Learn more about Hall Effect measurements with our free online webinar. [View it now!](#)



Let us offer advice on your application. [Contact an applications engineer online.](#)

Across a wide range of resistances, choose a Model 6220 or 6221 Current Source and Model 2182A Nanovoltmeter

A **Model 6220 or 6221 Precision Current Source**, combined with the **Model 2182A Nanovoltmeter**, is the industry's most sensitive solution for making Hall Effect measurements at various ranges of resistances. The Model 622X and Model 2182A are easy to use because the combination can be treated as a single instrument. Their simple connections eliminate the isolation and noise current problems that plague other solutions. And the second channel in the Model 2182 can be used to measure temperature. Furthermore this same combination of instruments along with Keithley's low level switching capability can also perform van der Pauw resistivity measurements and magneto-resistance studies. **Read our white paper on how new instruments can lock out lock-in amplifiers.**



Download the **Model 6220/6221** or **Model 2182A** datasheet.

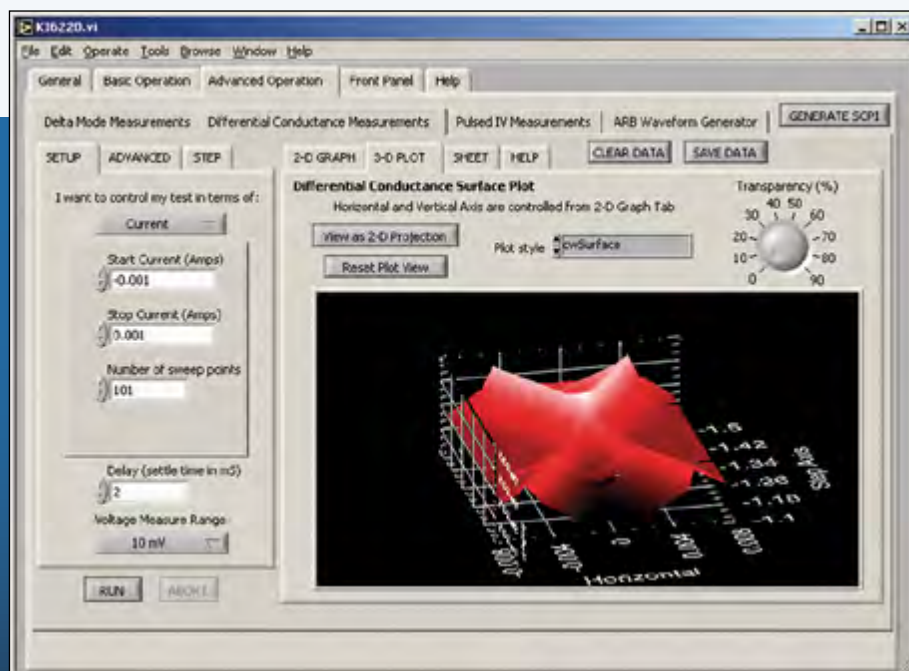

The 622X/2182A combination makes it simple to perform, analyze, and display differential conductance measurements.

Ready to request a quote or place an order?
Contact us online.

Explore the electrical characteristics of small crystals

Many materials researchers need to characterize the electrical properties of crystalline materials, such as their (anisotropic) conductivity and photoconductivity, as well as the temperature dependencies associated with these properties. Small crystals grown using a number of techniques can exhibit resistances as high as $10^{17}\Omega$, which must be measured in a specially designed measurement chamber, as well as in a Molecular Beam Deposition (MBD) system that allows making in-situ measurements during crystal or film growth. [Learn more.](#)



In this system configured for photocurrent measurements, the sample and the cable to the electrometer input are surrounded by a conductor at the same potential (guard) to prevent leakage currents.

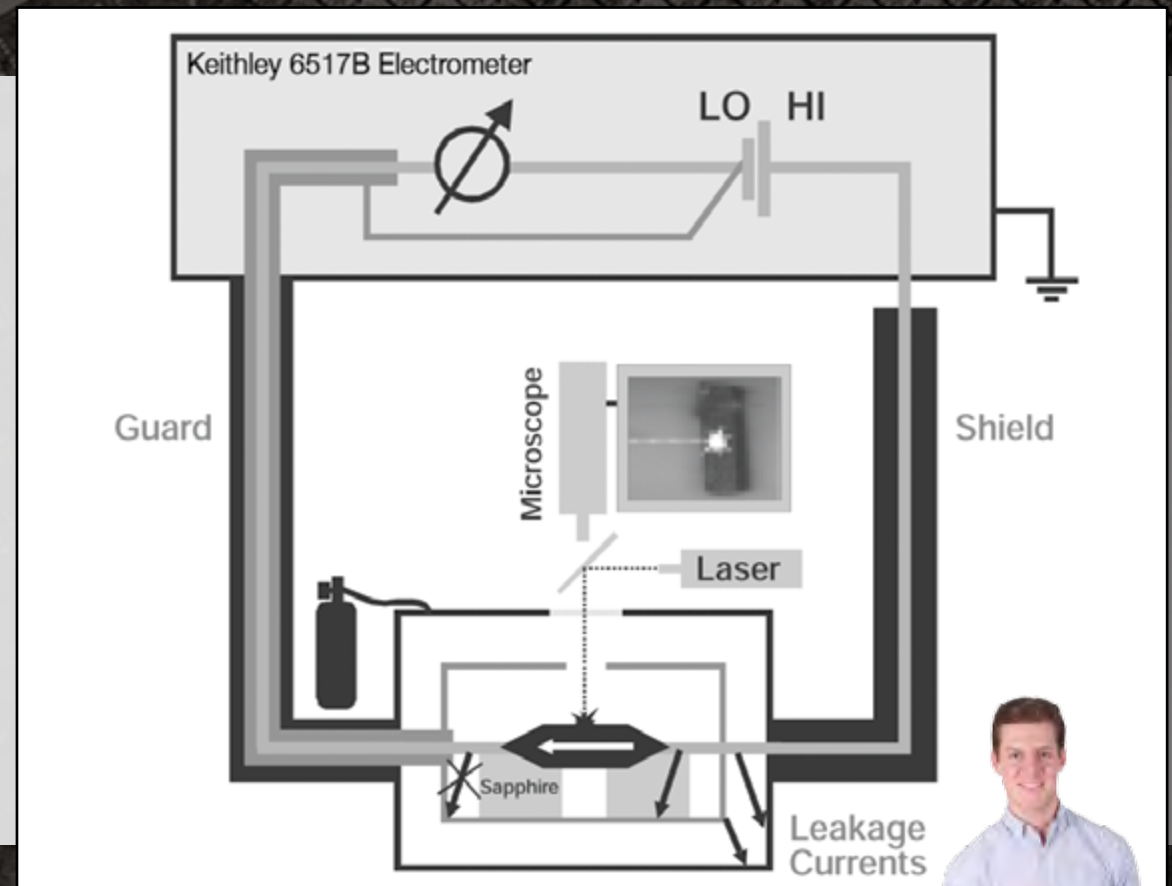

Let us offer advice on your application.
Contact an applications engineer online.

Want to learn more? Discover how to make high resistance measurements on small crystals in inert gas or high vacuum by reading our **online application note. Download your copy now.**

Find the answers you need with the Model 6517B Electrometer/High Resistance Meter

The 5½-digit **Model 6517B** offers accuracy and sensitivity specifications unmatched by any other meter of this type. A variety of features and options simplify measuring resistances as high as $10^{17}\Omega$, as well as volume and surface resistivity. With measurement speeds up to 425 readings/second, it's also significantly faster than competitive electrometers.

- Current measurements from 1fA to 20mA
- Voltage measurements from $10\mu\text{V}$ to 200V
- Resistance measurements from 50Ω to $10^{16}\Omega$
- Charge measurements from 10fC to $2\mu\text{C}$

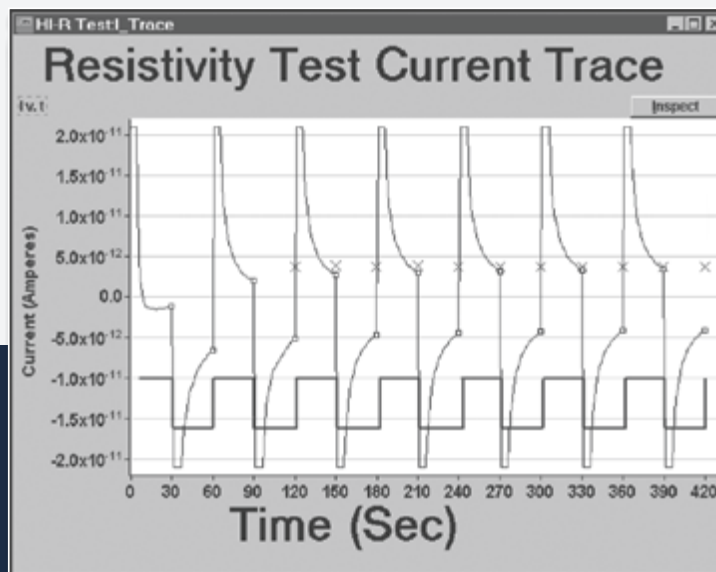

Alternating Polarity Method for Measuring Resistivity

The Model 6517B employs the Alternating Polarity method to measure high levels of volume or surface resistivity, virtually eliminating the effect of any background currents in the sample. When used with the optional Model 6524 software, users can see the actual current waveform that results from the applied Alternating Polarity DC voltage (the square wave). Users can easily determine whether the parameters used are appropriate for the material or device under test.

Need more detail?
Download the Model 6517B datasheet.

Ready to request a quote or place an order?
Contact us online.

Discover New Test Methods for Power Semi Devices and Materials

Many segments of the electronics industry, including the semiconductor industry, are focused on increasing energy efficiency, including boosting the efficiency of energy generation, transmission, and consumption. Power semiconductor devices are used as switches or blocking devices in such applications as motor control, voltage regulation and power conversion. New “greener” devices offer lower leakage, lower ON resistance, or both and create new requirements for test and measurement. New devices require a new approach to high power semi material and device testing. [Learn more.](#)

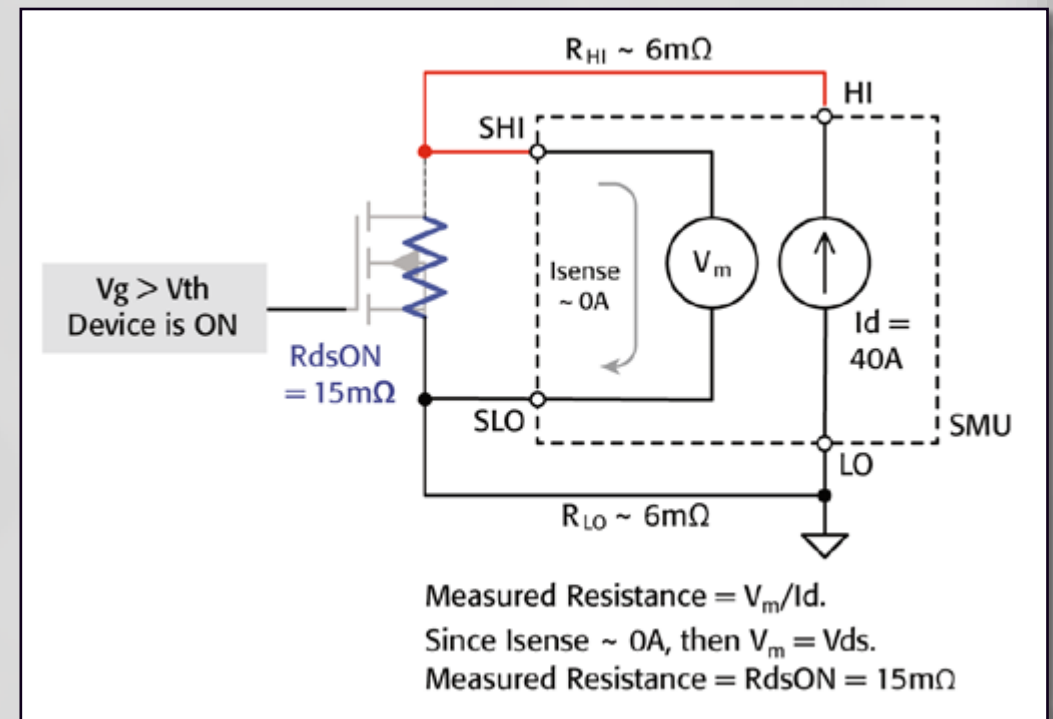

Use separate test leads to connect the device to the instrument's sense terminals. In this way, the voltage measured is only that across the device. The resulting resistance measurement will be a true measurement of the DUT resistance.



Learn how to test high power devices by [downloading our free application note.](#)

Learn how higher power semi devices will push instrumentation to new extremes. [View the article.](#)



Let us offer advice on your application. [Contact an applications engineer online.](#)

Perform Power Device Characterization at Higher Rated Voltages/Current Peaks

Keithley offers a broad spectrum of tools, both hardware and software, for power device characterization. A typical device test system could include the high voltage Model 2657A, one or two high current Model 2651A instruments, and up to three lower power SMU instruments (other Series 2600B instruments or the Model 4200-SCS semiconductor characterization system). System configuration is made safer and simpler with the optional new Model 8010 High Power Device Test Fixture or individual protection modules. TSP-Link[®] technology links Series 2600B instruments to form powerful multi-channel systems that rival the system speed of large ATE systems that cost tens of thousands of dollars more. [Learn more.](#)

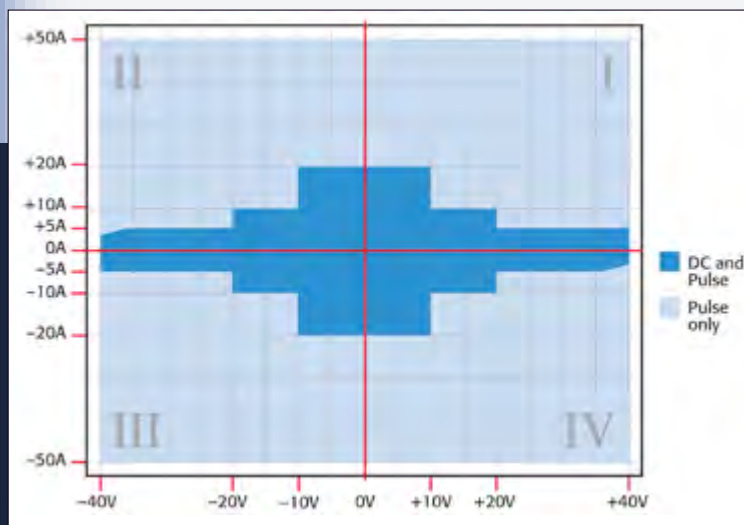

The Model 2651A has the widest current range available in the industry, with 2000W of pulsed power (40V@50A pulsed) capability and 200W of continuous DC power.

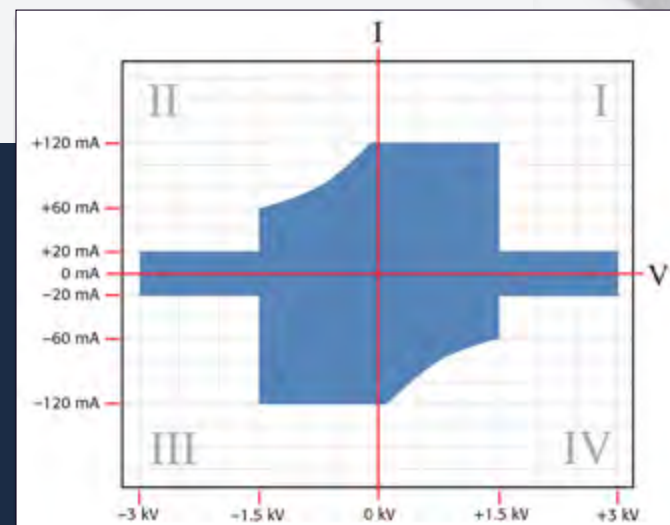

The Model 2657A offers the highest power available in the industry (up to 180W of either continuous DC or pulsed power) at such a high voltage (3,000V).

Download our Model 2651A High Power System SourceMeter[®] Instrument Data Sheet.

Download our Model 2657A High Power System SourceMeter[®] Instrument Data Sheet.

**Ready to request a quote or place an order?
 Contact us online.**

Keithley Instruments hosts an online applications forum to encourage idea exchange, discussions among users. [Join the discussion today.](#)

To learn more about how to enhance the productivity of your test and measurement applications, contact your local Keithley representative or [ask us a question online.](#)

Contact us by phone, fax, mail, or email:

KEITHLEY CORPORATE HEADQUARTERS

Keithley Instruments, Inc.
28775 Aurora Road
Cleveland, Ohio 44139
Phone: 440-248-0400
Toll-free: 800-552-1115
Fax: 440-248-6168
info@keithley.com

WORLDWIDE HEADQUARTERS

Within the USA: **1-888-534-8453**
Outside the USA: **+ 1-440-248-0400**
Email: applications@keithley.com
Additional contact information at
www.keithley.com

EUROPE

Germany: **(49) 89-84930740**

ASIA

China: **(86) 10-8447-5556**
Japan: **(81) 3-6714-30**
Korea: **(82) 2-6917-5000**
Taiwan: **(886) 3-572-9077**



Specifications are subject to change without notice. All Keithley trademarks and trade names are the property of Keithley Instruments, Inc. All other trademarks and trade names are the property of their respective companies.

A Greater Measure of Confidence

KEITHLEY

A Tektronix Company

KEITHLEY INSTRUMENTS, INC. ■ 28775 AURORA RD. ■ CLEVELAND, OH 44139-1891 ■ 440-248-0400 ■ Fax: 440-248-6168 ■ 1-888-KEITHLEY ■ www.keithley.com

BRAZIL
55-11-4058-0229
www.keithley.com

GERMANY
49-89-84930740
www.keithley.de

JAPAN
Tokyo: 81-3-6714-30
Osaka: 81-06-6396-1630
www.keithley.jp

MEXICO
52-55-5424-7905
www.keithley.com

TAIWAN
886-3-572-9077
www.keithley.com.tw

CHINA
86-10-8447-5556
www.keithley.com.cn

INDIA
080-30792600
www.keithley.in

KOREA
82-2-6917-5000
www.keithley.co.kr

SINGAPORE
01-800-8255-2835
www.keithley.com.sg

UNITED KINGDOM
044-1344-392450
www.keithley.co.uk

FRANCE
01-69868360
www.keithley.fr

ITALY
02-5538421
www.keithley.it

MALAYSIA
60-4-643-9679
www.keithley.com

SWITZERLAND
41-56-460-78-90
www.keithley.ch